

Model JK

Digital Pressure Gauge



DESCRIPTION

The Series JK digital pressure test gauge with 0.2 % full scale accuracy uses transducer technology and a stainless steel diaphragm for high overpressure protection. The transducer technology provides enhanced accuracy over the entire pressure range. The JK has no moving parts and thus, may provide a long life with fewer re-calibrations. The stainless steel NEMA construction also provides EMI and RFI protection. The JK provides high resolution with an easy to read digital display. There are no operator errors due to interpolation of hash marks or parallax errors.

The Model JKW is powered by one or two common 9 V alkaline batteries. The Model JKT is powered by a 110 Vac adapter. The Model JKV is powered by an 11 Vdc to 32 Vdc power supply.

FEATURES

- Ranges to 10000 psi
- 0.2 % accuracy
- Field selectable engineering units
- Available -18 °C to 82 °C [0 °F to 180 °F] operating temperature⁴
- Stainless steel construction
- 4½ digit display with 0.5 in height
- Customer recalibration
- 9 V battery power
- High/low capture and store
- On/off switch
- CE compliant (certain models, consult factory)
- Optional carrying case and panel mounting ring

Each unit has a membrane face with raised buttons and tactile feedback for setup and operation. The high, low, and clear buttons are easily accessible on this front membrane. Zero adjustment and zero offset/tare functions are standard on each unit. Calibration and setup parameters are stored on a memory chip to protect from loss even when power is interrupted. Unauthorized set ups and calibrations are also blocked with internal security. Various combinations of the front panel buttons can be de-activated.

Model JK

PERFORMANCE SPECIFICATIONS

Characteristic	Measure
Range	See additional specifications table
Accuracy	0.2 % ¹
Update speed	3 per second

ENVIRONMENTAL SPECIFICATIONS

Characteristic	Measure
Temperature, operating	-1 °C to 71 °C [30 °F to 160 °F] (-18 °C to 82 °C [0 °F to 180 °F] with optional NEMA 4 rating)
Rating	NEMA 2, std. (NEMA 4 optional except model JKT)

ELECTRICAL SPECIFICATIONS

Characteristic	Measure
Display	LCD, 4 1/2-digit, 1,3 cm [0.5 in] high
Power supply, Model JKW	1 or 2 9-volt batteries (included)
Power supply, Model JKT	110 volt ac adaptor @ 60 Hz (included)
Power supply, Model JKV	11 Vdc to 32 Vdc @ 100 mA
Electrical connection	0,9 m [3 ft] cable (std.) for model JKV
Low battery indication	Standard on model JKW
Calibration data	Stored on memory chip
High and low capture	Standard

MECHANICAL SPECIFICATIONS

Characteristic	Measure
Pressure port	1-4/18 NPT male (300 psi and below) 9/16-18 UNF - 2B female straight thread with SAE spec J514 o-ring boss (500 psi and above)
Face membrane	Tactile feedback raised buttons
Case material	Stainless steel
Wetted parts	Stainless steel

ADDITIONAL SPECIFICATIONS

Pressure range (psi)	1	5	15	30	50	100	200	300	500
Max. safe over pressure (psi)	10	25	75	150	250	500	1000	1200	1500
Incremental display steps	0.001	0.005	0.01	0.02	0.05	0.1	0.1	0.2	0.5

Pressure range (psi)	750	1000	1500	2000	3000	5000	7500	10000
Max. safe over pressure (psi)	1500	2000	3000	4000	6000	7500	12000	15000
Incremental display steps	0.5	1	1	1	2	5	5	5

MOUNTING DIMENSIONS AND CHARACTERISTICS

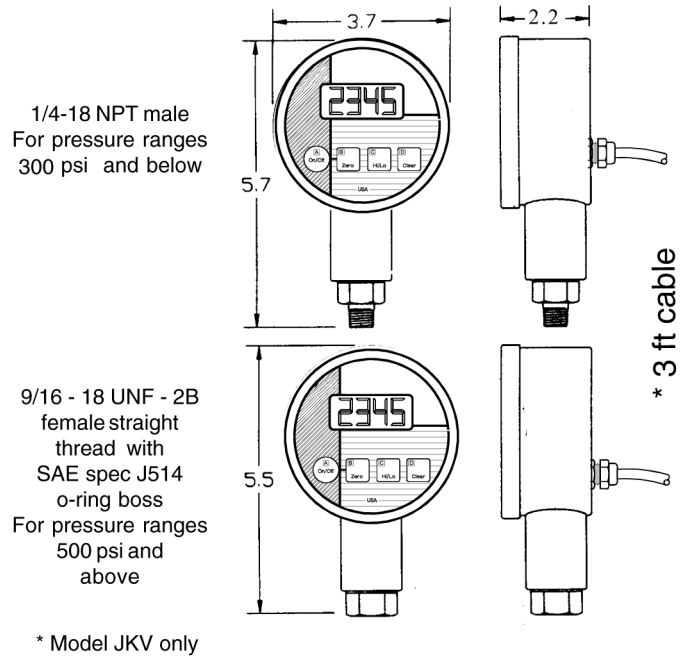

Request certified drawing before designing mountings or fixtures.
Specifications subject to change without notice.

For reference only



Model JK

Digital Pressure Gauge

ORDER GUIDE

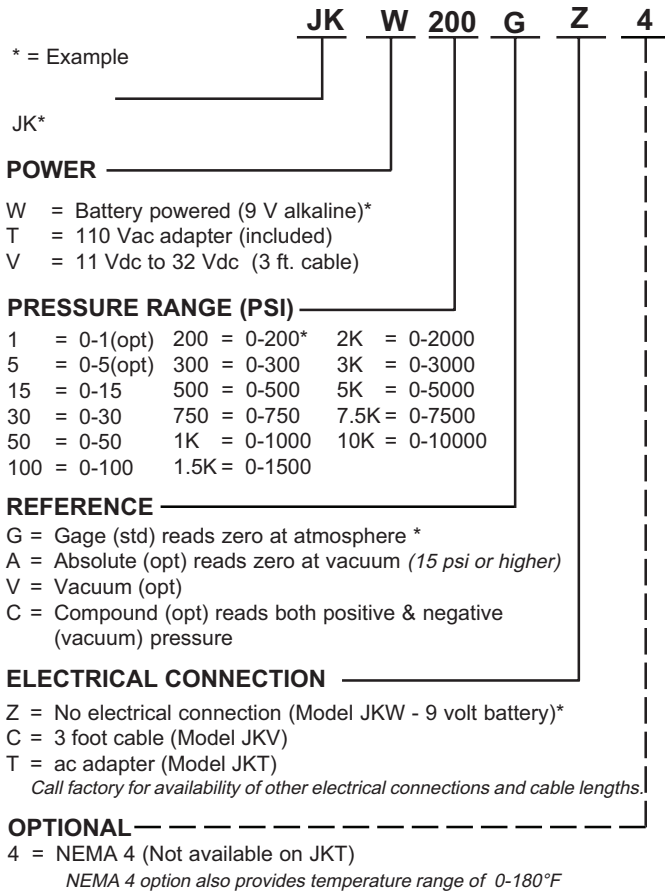

FIELD SELECTABLE STANDARD UNITS OF MEASURE

Each gauge has the following scaling built in for field selection:

Bar = Bar	Ft H2O = Feet of water
mBar = Millibar	In H2O = Inches of water
kPa = Kilopascals	In Hg = Inches of mercury
MPa = Megapascals	mmHg = mm of mercury

Consult factory for other units of measure not listed

NOTES

1. Accuracies stated are for best fit straight line for all errors including linearity, hysteresis and repeatability through zero.
2. Consult factory for optional units of measure.
3. Consult factory for optional electrical connectors and cable lengths.
4. -18 °C to 82 °C [0 °F to 180 °F] operating temperature only with optional NEMA 4 rating.

Warranty. Honeywell warrants goods of its manufacture as being free of defective materials and faulty workmanship. Honeywell's standard product warranty applies unless agreed to otherwise by Honeywell in writing; please refer to your order acknowledgement or consult your local sales office for specific warranty details. If warranted goods are returned to Honeywell during the period of coverage, Honeywell will repair or replace, at its option, without charge those items it finds defective. **The foregoing is buyer's sole remedy and is in lieu of all warranties, expressed or implied, including those of merchantability and fitness for a particular purpose. In no event shall Honeywell be liable for consequential, special, or indirect damages.**

While we provide application assistance personally, through our literature and the Honeywell web site, it is up to the customer to determine the suitability of the product in the application.

Specifications may change without notice. The information we supply is believed to be accurate and reliable as of this printing. However, we assume no responsibility for its use.

For more information about Sensing and Control products, visit www.honeywell.com/sensing or call +1-815-235-6847

Email inquiries to info.sc@honeywell.com

WARNING PERSONAL INJURY

- DO NOT USE these products as safety or emergency stop devices or in any other application where failure of the product could result in personal injury.

Failure to comply with these instructions could result in death or serious injury.

WARNING MISUSE OF DOCUMENTATION

- The information presented in this catalogue is for reference only. DO NOT USE this document as product installation information.
- Complete installation, operation and maintenance information is provided in the instructions supplied with each product.

Failure to comply with these instructions could result in death or serious injury.

Sensing and Control
 Automation and Control Solutions
 Honeywell
 1985 Douglas Drive North
 Golden Valley, MN 55422 USA
 +1-815-235-6847
www.honeywell.com/sensing

Honeywell